

GALE FORCE

VAF-16R

Ventilation Manual



Dry Air
TECHNOLOGY

313 North Oak Street • Burlington, WA 98233 • USA
Tel: 001-360-755-9176 • Fax: 001-360-755-9236
Toll Free U.S. & Canada: **1-888-755-9176**
info@dryairtech.com • www.dryairtech.com



Congratulations on your purchase of a new VAF series fan by Dry Air Technology, Inc. This Vane Axial Fan has been designed to offer you the reliability, durability and portability you need for the toughest job.

The Gale Force is a breakthrough in structural drying! With more CFMs and less amps it is the best choice for the latest “in-place” drying techniques. With only 2.5 amps per unit, contractor set up hassles are a thing of the past and the reduced heat load on the environment allows the dehumidifiers to create even drier air, resulting in overall faster drying time than what can be achieved with a standard carpet dryer.

To get the most out of your Gale Force simply place fans along the perimeter of the room, and position each fan at a 30 degree angle to the wall. All airflow must be in the same direction. Then, place one or two fans with stand, depending on the size of the room, in the center of the room with the fan blowing directly on the carpet or floor. Move units each day to a new location along the wall.

Please read this owner’s manual carefully to insure that you get the most from your unit.

SAFETY INFORMATION

CAUTION!

Unit operates on alternating current: 110/120 volt, 60 HZ

Do not operate your vane axial fan with a cut or frayed power cord. Do not unplug your unit by pulling on its cord. Grasp the plug firmly and pull it out of the wall socket or power receptacle. The plug has a safety ground pin installed that must not be removed. If the pin is damaged or missing, have the power cord replaced at once. Visually inspect the power cord before each use. Ignoring these safety precautions may result in a fire or an electric shock.

Never operate electrical equipment in standing water. There is a shock hazard.

Never drop the unit. Sudden and severe impact may result in damage to internal components.

Your vane axial fan should never be operated with the safety grills removed. Personal injury may result.

Drop cloths or other loose fabrics can be drawn against the unit thereby restricting airflow. This condition may cause the unit to overheat. Keep the air inlet clear of any obstructions.

Save the shipping carton in case your VAF fan must be returned for repair.

This unit should never be serviced or cleaned while it is plugged into a live electrical power source.

WARNING: Ignoring these safety precautions may result in serious personal injury.

Vane Axial Fan

GALE FORCE

OPERATING INSTRUCTIONS

The unit as packaged is ready to be put into service. If you have a 220V model, attach the appropriate plug for your region.

Inspect the unit completely for any shipping damage. Place the unit on the ground or on a very stable platform.

Plug the unit into a grounded alternating current circuit and switch the unit on.

MAINTENANCE

Warning

Disconnect the unit from the power supply before cleaning or servicing.

Before each use the unit should be inspected for damage, clogged inlet or outlet, or any excess buildup of foreign material. When the unit is first turned on, check for excessive vibration, which could indicate a major problem. If the unit vibrates, have a service technician inspect the unit for the problem.



SPECIFICATIONS FOR GALE FORCE

VOLTAGE	110/120V
FREQUENCY	60 HZ
MOTOR	¼ HP
CURRENT	2.5 AMPS
RPM	1625
HEIGHT	22"
WIDTH	21"
LENGTH	15 ½"
WEIGHT	34 lbs

Trouble Shooting

Problem	Cause	Solution
Unit will not run.	<ol style="list-style-type: none"> 1. No power to unit. 2. Switch not on. 3. Switch is faulty. 4. Faulty/broken cord or motor wire. 	<ol style="list-style-type: none"> 1. Plug unit in. Check circuit breaker. 2. Place in "ON" position. 3. Replace switch. 4. Perform continuity check, using volt/amp meter. Repair/replace faulty broken wire.
Unit runs but fan makes loud scraping noise.	<ol style="list-style-type: none"> 1. Unit has been severely jolted causing fan to rub against housing. 2. Unit has been severely jolted causing housing to deform. 	<ol style="list-style-type: none"> 1. Remove motor and replace damaged motor mounts. 2. Replace fan blade.
Unit runs but vibrates excessively.	<ol style="list-style-type: none"> 1. Severe jolt has bent motor shaft causing unit to be out of balance. 2. Fan blade damaged. 3. Dirt build up on one side of fan blade. 	<ol style="list-style-type: none"> 1. Remove and replace motor. 2. Replace blade if necessary. 3. Clean fan blade.
Unit runs but fan does not turn.	<ol style="list-style-type: none"> 1. Fan is jammed against housing. 2. Capacitor wire has broken/come loose, capacitor has failed. 3. Housing has been damaged such that it presses on fan blade. 	<ol style="list-style-type: none"> 1. Remove motor and replace damaged motor mounts. Replace fan blade if necessary. 2. Repair/replace wires/capacitor as necessary. 3. Replace housing/unit as necessary.
Unit runs briefly, then shuts off on overload.	<ol style="list-style-type: none"> 1. Motor bearings are failing or motor has developed an internal electrical fault. 2. Intake grill and/or exhaust grill is obstructed. 3. Excessive duct length. 	<ol style="list-style-type: none"> 1. Replace motor. 2. Remove obstruction. 3. Reduce duct length to recommended maximum.



Dry Air
TECHNOLOGY

313 North Oak Street Burlington, WA 98233 USA
 Tel: 001-360-755-9176 Fax: 001-360-755-9236
Toll Free U.S. & Canada: 1-888-755-9176
info@dryairtech.com • www.dryairtech.com

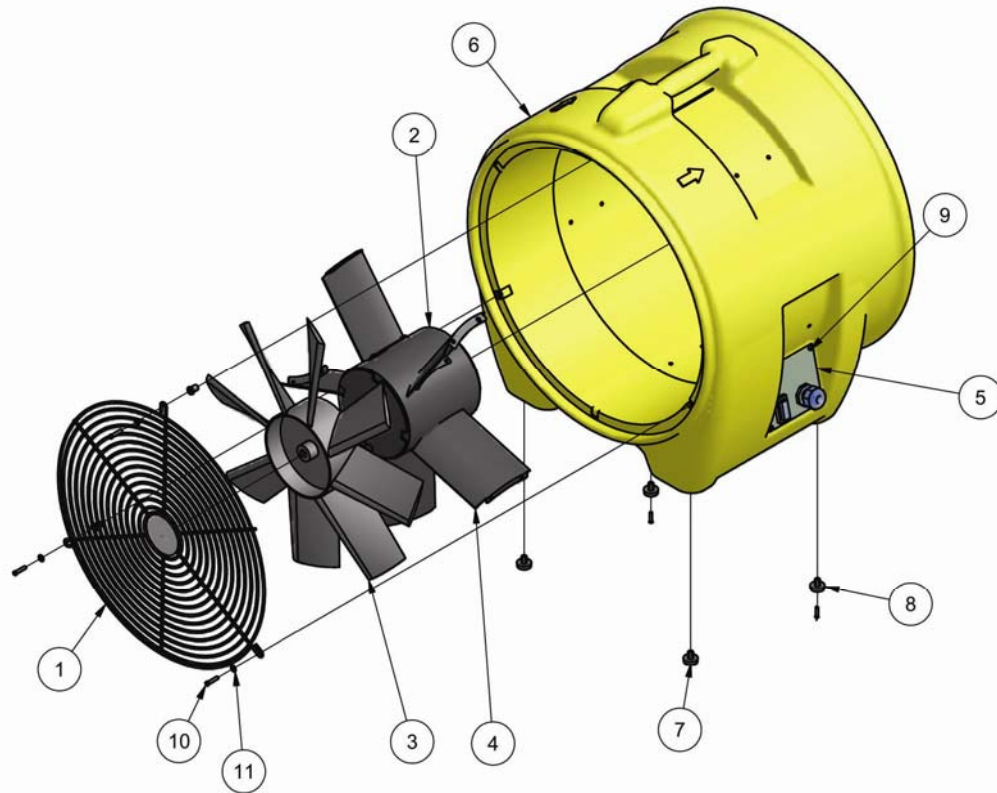

Parts List

Item	Qty	Part Number	Description
1	1	AF-00C-M5A10524	Intake Grill Spiral Wound
	1	AF-00C-M5A10525	Outake Grill Spiral Wound
2	1	AF-00M-M1A10273	115V 60HZ 2.5 amp Motor
3	1	AF-00M-P4A10270	16" Fan Blade
4	5	AF-00C-M1NN0403	Vane 16" Motor Mount
5			(see diagram on next page)
6	1	AF-00C-P4A20368	16" Shell
7	2	GN-00C-RNN10006	Tempest/Axial Feet, P/N 2544
8	2	AF-00F-RNA10268	1.5" Foot
	2	AC-00F-S5AN0034	¼ Flat Washer 18-8 St
	2	CF-00F-R4A10001	Well Nut ¼-20
	2	GN-00F-Z3AN0267	2" PPH MS 1/4X20 Zinc Bolt
9	4	CF-00F-S2AN0003	#8X1/2 Phil Pan T/S 18-8ss
10	7	AF-00C-S3AN0102	8/32" X 1/2" Screws
11	7	AF-00F-S5AN0051	#10 Flat Washers
	1	AF-00E-NNHN0279	7.5MF 370V Capacitor
	2	AF-00C-M6N10383	Swivel Mount
	18	GN-00F-S1NN0202	Rivet 3/16" Dia x 3/4" Grip Alum

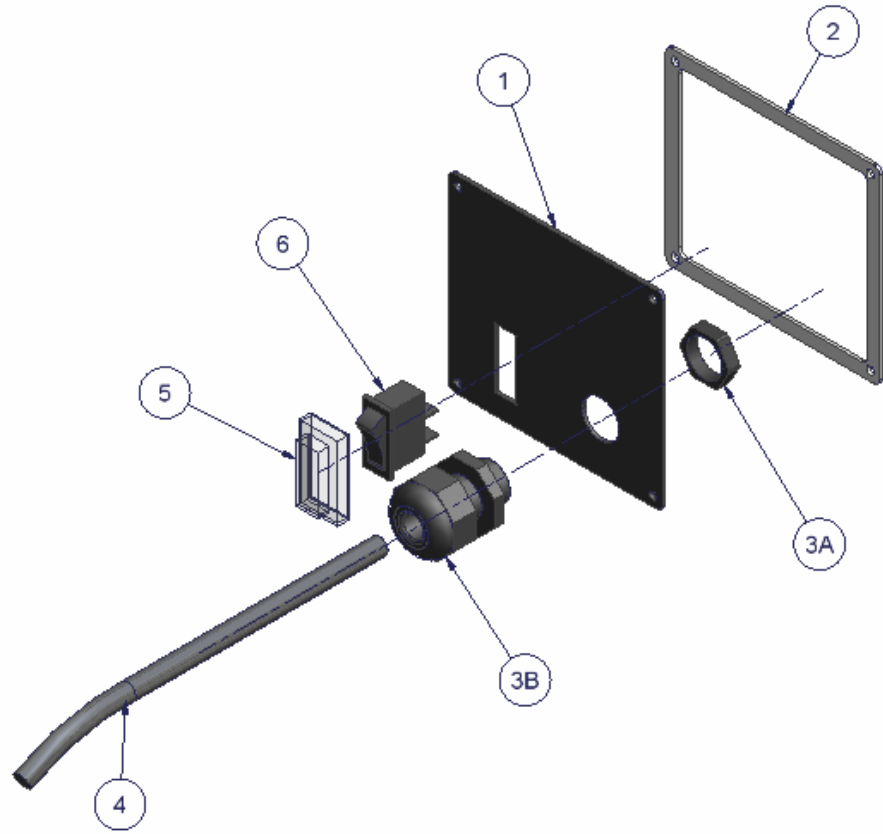

Parts List

Item	Qty	Part Number	Description
1	1	AF-00C-M3A10359	Switch Plate, VAF 12E/16R
2	1	AF-00C-R6A10360	Gasket, Switch Plate, VAF 12/16
3A	1	AF-00E-PNN10015	Strain Relief-LQ TIGHT
3B	1	AF-00E-PNN10015	Strain Relief-LQ TIGHT
4	1	CF-00E-N4A10004	Power cord 20' 16/3 SJT-WA CEE
5	1	GN-00C-R3NN0335	Cover, Rocker Switch
6	1	GN-00E-P3B10218	ON/OFF Rocker Switch, BLK



RETURN AND REPAIR POLICY

RETURN AUTHORIZATION NUMBER (RMAs)

- Before a purchaser ships a product back to Dry Air Technology, the purchaser must obtain a valid RMA number by calling 1.888.755.9176. Boxes received without an authorized RMA number will be refused. When preparing the item for return please ensure that the RMA number is clearly visible on a label on the outer covering.
- Please have the following information ready when requesting an RMA number:
 1. Reason for return.
 2. Product (model) numbers and quantity to be returned.
 3. Serial numbers of each product.
 4. Customer name and return address.
 5. Company where product was purchased and when it was purchased.
 6. Copy of invoice and/or packing slip.

PACKAGING

Items must be returned in its original packaging. This includes the plastic sleeve the product came in, along with cardboard separators. Original packaging will help protect unit from freight damage upon return.

NON-RETURNABLE ITEMS

Items may not be returned to Dry Air Technology if items contain customer markings, stickers or damage.

The following conditions are NOT covered by our warranty and can be refused for credit or return:

1. Normal "wear and tear"
2. Improper packaging by customer causing freight damage.
3. Failure to provide a suitable operating environment
4. Use of the product for purposes other than those for which it was designed
5. Failure to monitor or operate the product in accordance with applicable seller specifications and good industry practice.
6. Unauthorized attachment, removal, or alteration of any part of the product
7. Unusual mechanical, physical, or electrical stress, scratches or dents
8. Modifications or repairs done by parties other than the seller
9. Abuse, misuse, neglect, or accidental damage

DAMAGED FREIGHT

Though it is a very rare occasion, shipping containers and/or their contents can be damaged during shipping. Open and inspect every package regardless of how the box looks. If the box is physically damaged and/or the parts are damaged, you must notate on the bill of lading that the box and/or the parts are damaged before you accept the shipment. DO NOT sign the bill of lading without notating the damage. Freight claims cannot be resolved without this notation from the recipient. If the box is fine and after opening and testing the unit you discover any internal damages call us immediately. In no case can we allow longer than 7 days to file a claim.

Dry Air Technology 10 Year Limited Warranty **Axial and Centrifugal Air Flow Products**

Warrantor: Dry Air Technology, 313 North Oak Street, Burlington, WA 98233. Telephone: 888-755-9176, local: 360-755-9176, fax: 360-755-9236.

Who Is Covered: This warranty extends to the original end-user of axial and centrifugal air flow devices manufactured by Dry Air Technology, and may not be assigned or transferred.

Warranty Period: The term of the warranty coverage from the date of purchase is:
10 years on the cabinet, chassis and housing
1 year on parts, labor and reasonable shipping costs, excluding filters and accessories.

Warranty Coverage: Dry Air Technology warrants that, for one year, axial and centrifugal air flow devices manufactured by Dry Air Technology will operate free from defects in material or workmanship, or Dry Air Technology, at its option, will repair or replace the defective part(s), free of charge.

Dry Air Technology further warrants that for a period of ten (10) years, the cabinet, chassis and housing of axial and centrifugal air flow devices manufactured by Dry Air Technology, will be free from defects in material or workmanship, or Dry Air Technology, at its option, will repair or replace the defective part(s), provided that all labor and shipping costs for the defective part(s) shall be borne by the end-user.

This warranty does not cover any defect, malfunction, etc. resulting from misuse, abuse, lack of normal care, corrosion from chemicals, freezing, tampering, modification, unauthorized or improper repair or operation, accident, acts of nature or any other cause beyond Dry Air Technology's reasonable control.

End-User Responsibilities: Warranty service must be performed by a firm or individual authorized by Dry Air Technology. If the end-user is unable to locate or obtain warranty service from an authorized firm or individual, he should contact Dry Air Technology at the above location, which will arrange for covered warranty service. All covered warranty service will be performed during normal business hours.

Limitations and Exclusions: If any part of a axial or centrifugal air flow device manufactured by Dry Air Technology is repaired or replaced, the new part shall be warranted only for the remainder of the original warranty period of the air flow device (but all warranties will be extended by the period of time, if any, that the Dry Air Technology air flow device is out of service while waiting for covered warranty service).

UPON THE EXPIRATION OF THE WRITTEN WARRANTY APPLICABLE TO THE DRY AIR TECHNOLOGY AIR FLOW DEVICE OR ANY PART THEREOF, ALL OTHER WARRANTIES IMPLIED BY LAW, INCLUDING MERCHANTABILITY AND FITNESS FOR A PARTICULAR PURPOSE, SHALL ALSO EXPIRE. ALL WARRANTIES MADE BY DRY AIR TECHNOLOGY ARE SET FORTH HEREIN, AND NO CLAIM MAY BE MADE AGAINST DRY AIR TECHNOLOGY BASED ON ANY ORAL WARRANTY. IN NO EVENT SHALL DRY AIR TECHNOLOGY, IN CONNECTION WITH THE SALE, OPERATION, REPAIR OR REPLACEMENT OF ANY DRY AIR TECHNOLOGY AIR FLOW DEVICE OR PART THEREOF BE LIABLE UNDER ANY LEGAL THEORY FOR ANY SPECIAL, INDIRECT OR CONSEQUENTIAL DAMAGES INCLUDING WITHOUT LIMITATION WATER DAMAGE (THE END-USER SHOULD TAKE PRECAUTIONS AGAINST SAME), LOST PROFITS, DELAY, OR LOSS OF USE OR DAMAGE TO ANY REAL OR PERSONAL PROPERTY.

Some states do not allow limitations on how long an implied warranty lasts, and some do not allow the exclusion or limitation of incidental or consequential damages, so one or both of these limitations may not apply to you.

Legal Rights: This warranty gives you specific legal rights, and you may also have other rights which vary from state to state.

DRY AIR TECHNOLOGY, BURLINGTON, WASHINGTON