

# SPECIFICATIONS

**PROCESS AIR VOLUME-** 1000 SCFM  
**DUCT CONNECTIONS-** 8" ROUND  
**PROCESS EXTERNAL STATIC-** 2 EXSP  
**PROCESS BLOWER H.P.-** 3 HP  
**NOMINAL MOISTURE REMOVAL-** 3-40 LB./HR.  
**REACTIVATION VOLUME-** 350 SCFM  
**REACTIVATION EXTERNAL STATIC-** 2 EXSP  
**BLOWERS-** DIRECT DRIVE

**REACTIVATION BLOWER H.P.-** .75 HP  
**UNIT FLA-** 28.5 AMPS @ 480V/ 3 PHASE  
**DISCONNECT-** 60 AMP FUSED @ 480V/ 3 PH  
**QUICK TURN DDDR SCREWS-** STAINLESS STEEL  
**CABINET/SKID CONSTRUCTION-** ALUMINUM  
**UNIT TOTAL WEIGHT-** 730 lbs.  
**ELECTRIC HEAT KW** 15 KW.  
**OPTION POWER FEATURE**  
**240 VOLT CONVERSION**  
**UNIT FLA-** 52 AMPS @ 240V/ 3 PHASE

## SAFETY SHUTDOWN FEATURES-

**ROTATION SHUTDOWN**  
**LOW TEMP SHUTDOWN**  
**HIGH TEMP SHUTDOWN**  
**AIR FLOW SHUTDOWN**

# MODEL DH-1000 E

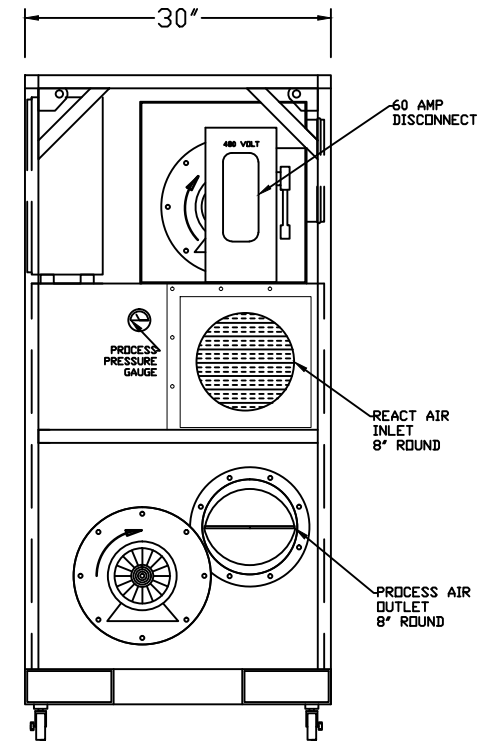
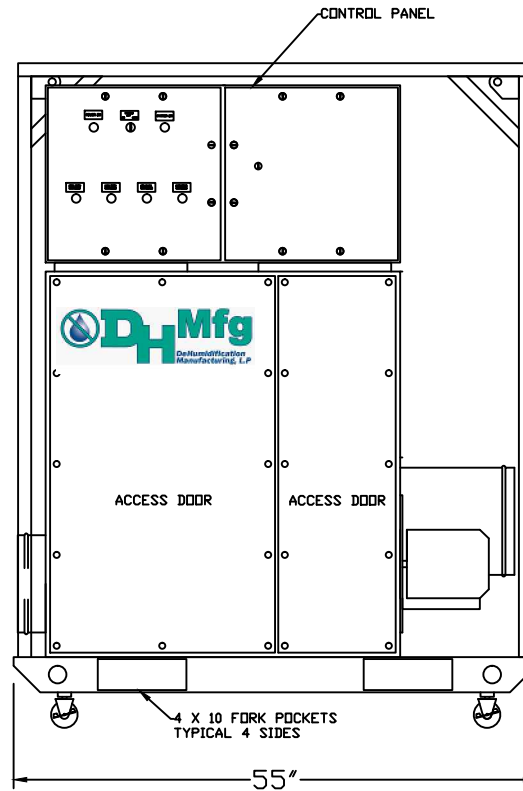
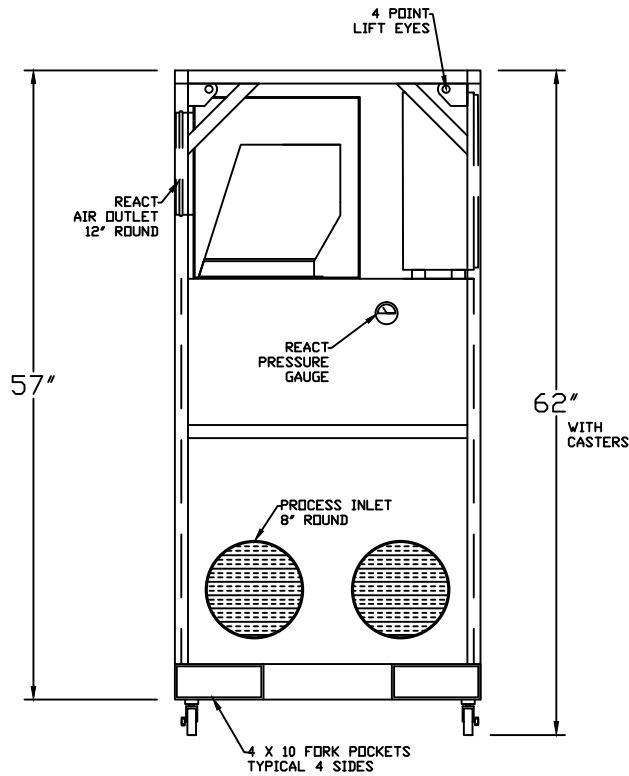

		DeHumidification Manufacturing L.P.	
		DRAWN BY:	TITLE: DH-1000 SPEC SHEET
THIS DRAWING IS THE PROPERTY OF DEHUMIDIFICATION MANUFACTURING L.P. DO NOT DISTRIBUTE WITHOUT THE EXPRESS WRITTEN PERMISSION OF DHM.		ISSUED BY:	DATE: 1-11-2013
		DESIGNED BY:	SHEET 1 OF 1